

Curriculum Matters

Y6 Autumn 2

English



Maths

Children will read and respond to a selection of non chronological reports. We will spend time analysing and investigating language and features such as organisational devices. Children will write their own report on the Maya and will be encouraged to evaluate and edit their writing with a view to improving it.

Sentence level work will focus on using a range of active and passive sentences and using relative clauses to expand sentences. Children will also explore an increasing range of punctuation, including brackets, commas and dashes to show parenthesis

English Targets:

To ensure writing uses a range of sentence types and interesting features for the reader.

Units of work within mathematics this half term will include:

- Securing written methods for addition, subtraction and multiplication
- Long division (4 digits by 2 digits)
- Factors and multiples
- Using common factors to simplify fractions
- Performing operations with fractions including adding and subtracting fractions with different denominators
- Applying knowledge to word problems and real-world situations
- Embedding of key skills in Friday sessions

Mathematics Targets:

Use an efficient formal written method for all four operations (+-x÷) in order to solve multi-step problems.

Music

Music lessons with Mrs Stone will continue on Wednesday afternoons and the children will be learning how to play the recorder.

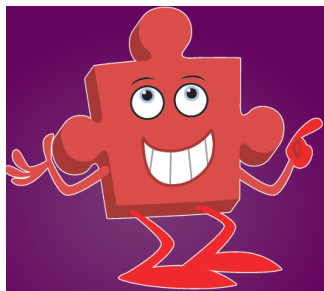

PSHE

We will be following our Jigsaw scheme with this half term's focus on celebrating differences.

PE

Tameside Sports Coaches will continue to deliver weekly PE lessons on Wednesday afternoons. Please ensure children come to school in the correct PE kit (white, plain t shirt and black plain shorts or joggers, plain black trainers).

Computing

This half term, we will be developing our word processing skills, focusing on plugging gaps that are still evident from prior years (due to covid).

Science: Electricity and Light

Children will be helped to develop the skills of:

- Planning and carrying out practical investigations with electronic circuits
- To draw and answer questions about circuit diagrams.
- To investigate changes in voltage and the brightness of bulbs
- Learning about how we see objects because light is reflected into our eyes
- Explaining conclusions in terms of scientific knowledge and understanding and focusing on the use of scientific vocabulary

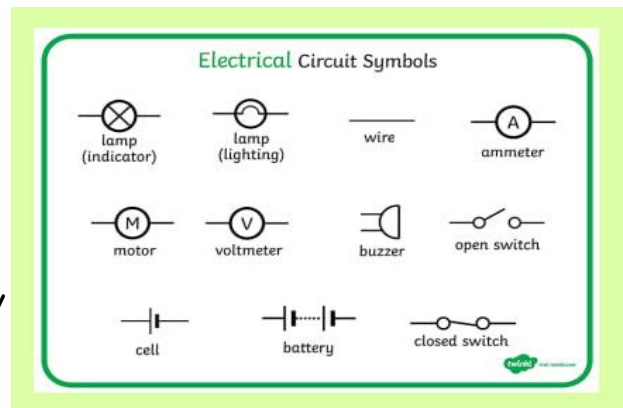

RE - Values and adversity

We will look at applying religious values of tolerance and forgiveness to the 21st Century and also 'what religions say when life gets hard.



Homework

Homework will continue as per last half-term:

- English and Maths are given out on Wednesday and need to be in by Monday
- Spellings will be given on a Friday and tested the following Thursday.

Please remind your child to bring their homework in on time to help them get into good habits for high school.